



COLORDMD

Installation Instructions for **White Star**

Congratulations on the purchase of a new ColorDMD display. The ColorDMD will enhance your pinball machine by introducing *color* to the dot matrix display graphics produced by the game.

Tools Required:

- 1/4" Nut Driver
- Phillips Screwdriver



Be sure to turn **OFF** the power to the pinball machine before installing the ColorDMD display.

STEP **1** Carefully remove the translite from the backbox and then lower the speaker panel to the position shown in Fig. A to gain access to the backbox.

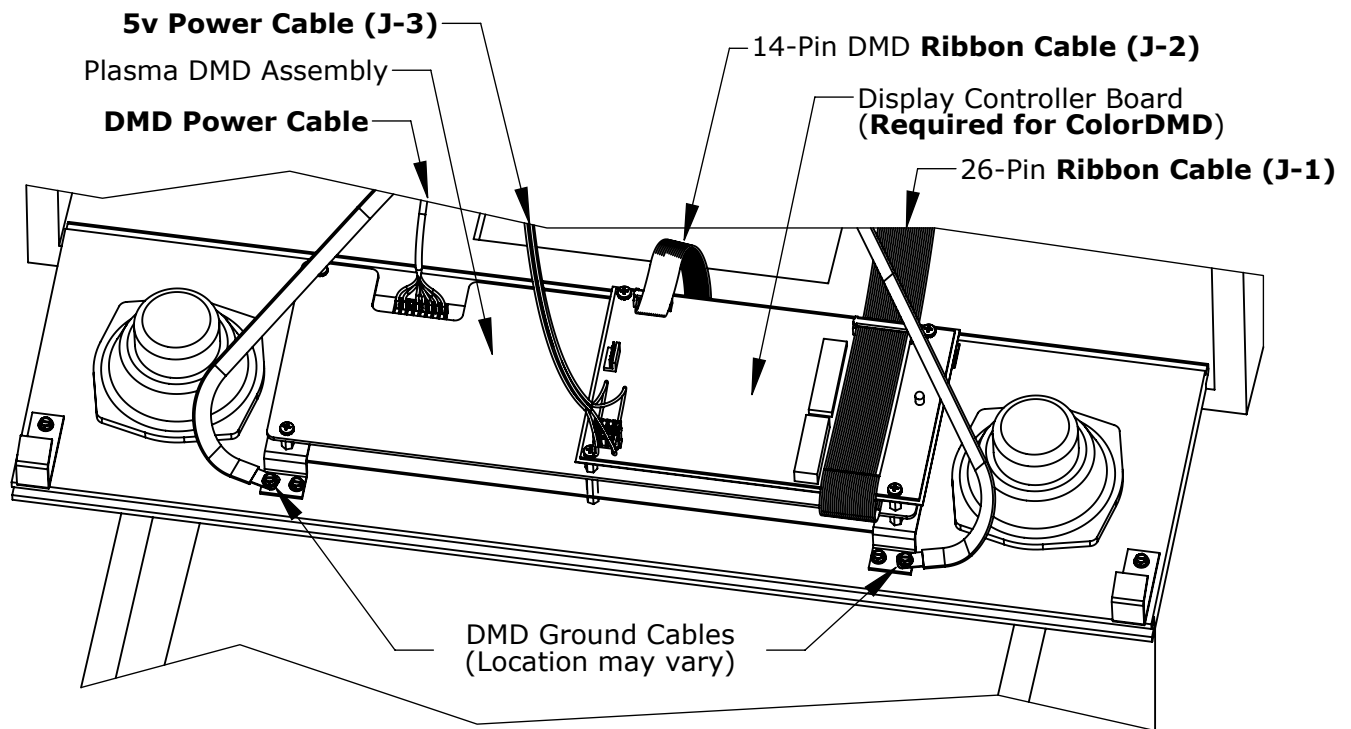

Figure A

STEP **2** Disconnect the DMD power cable from the DMD and secure it aside (it is not used for the ColorDMD). Also disconnect the 5v power cable at J-3 on Display Controller Board.

STEP **3** Disconnect both ribbon cables from J1 and J2 on the Display Controller Board. **Remove the Display Controller Board from the metal bracket on the DMD assembly.**

STEP **4** Remove the eight DMD assembly mounting screws. **Remove the original DMD assembly from the game and store it in a safe place.**

- STEP **5** **Ensure the RF Shield (if present) remains under the Display Controller Board with metallic side facing down.** Using the 4 screws supplied in the ColorDMD mounting bracket, fasten the Display Controller Board to the ColorDMD in the orientation shown in Fig. B.

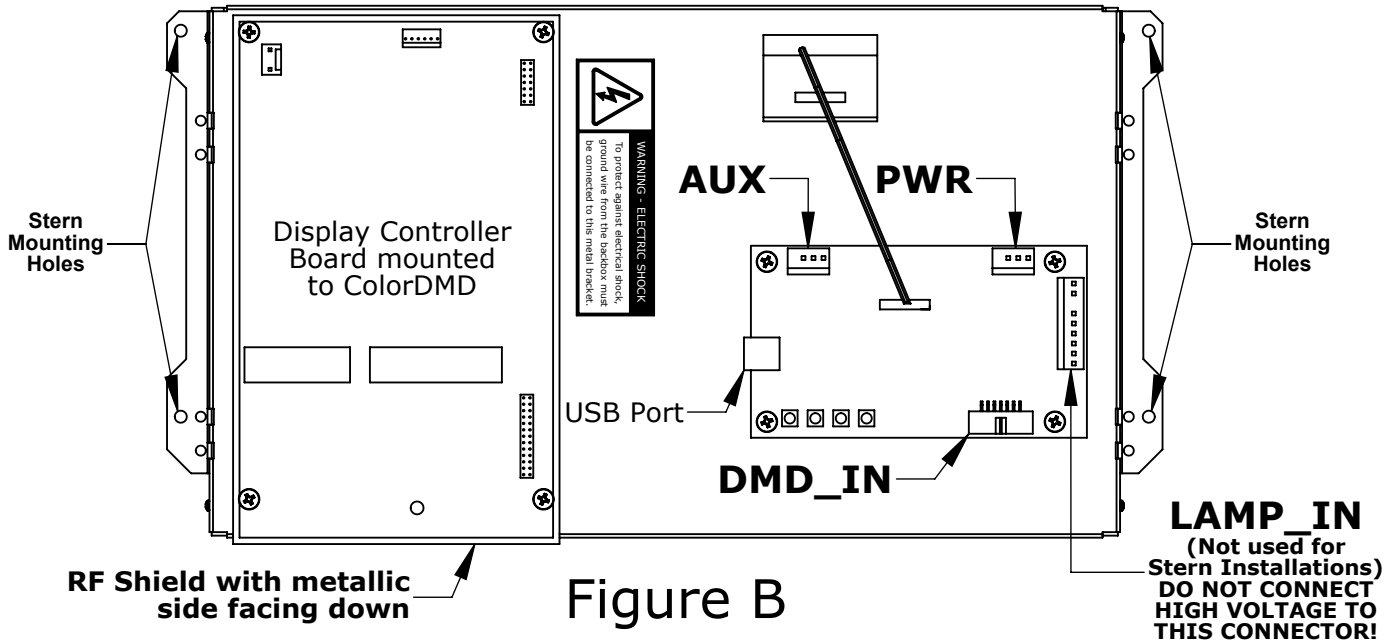

Figure B

- STEP **6** Remove the protective film from the front side of the new ColorDMD display.

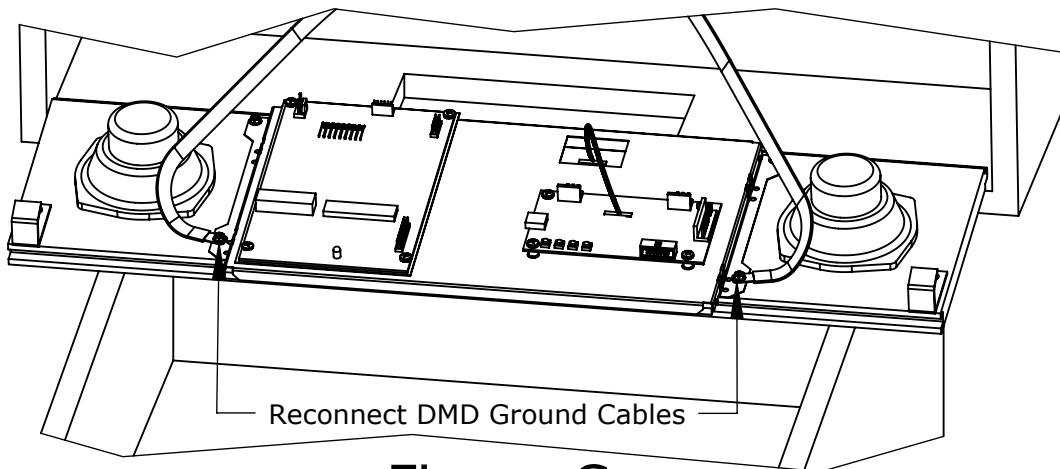

Figure C

- STEP **7** Position the ColorDMD face down (centered in the orientation shown in Fig. C) on the speaker panel and align the four Stern mounting holes (see Fig. B).
- STEP **8** Use the four included ColorDMD mounting screws to fasten the ColorDMD display to the speaker panel. **Make sure to reconnect the DMD Ground Cables to ColorDMD** (see Fig. C).



WARNING. Electric Shock Hazard - To protect against accidental electric shock, **DO NOT** operate the game without ensuring that the ColorDMD metal bracket is electrically grounded.

- STEP **9** Locate the included ColorDMD Power Cable. One end of the cable has a single connector (see Fig. D). Plug this connector into the PWR header (see Fig. B) on the ColorDMD circuit board.

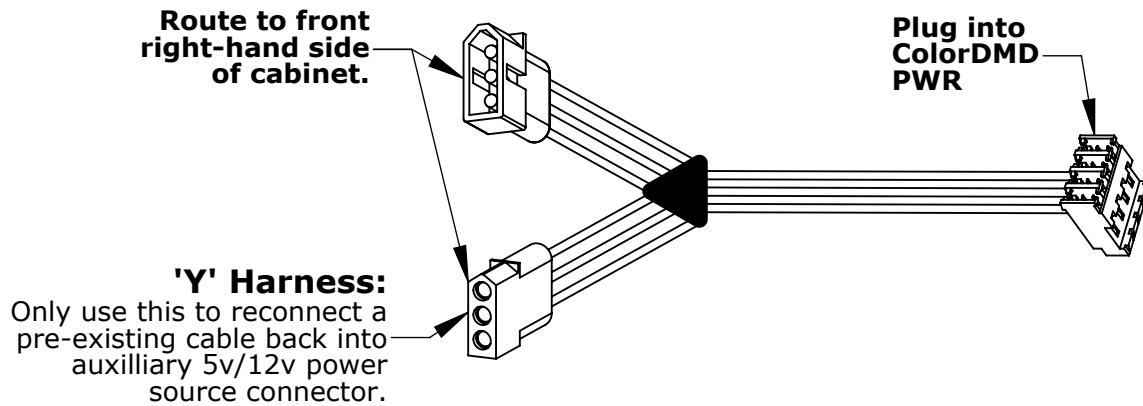

Figure D

- STEP **10** Route the other end of the new ColorDMD Power Cable down through bottom of backbox into the cabinet and over to the front right-hand side of the game. (see Fig. E).

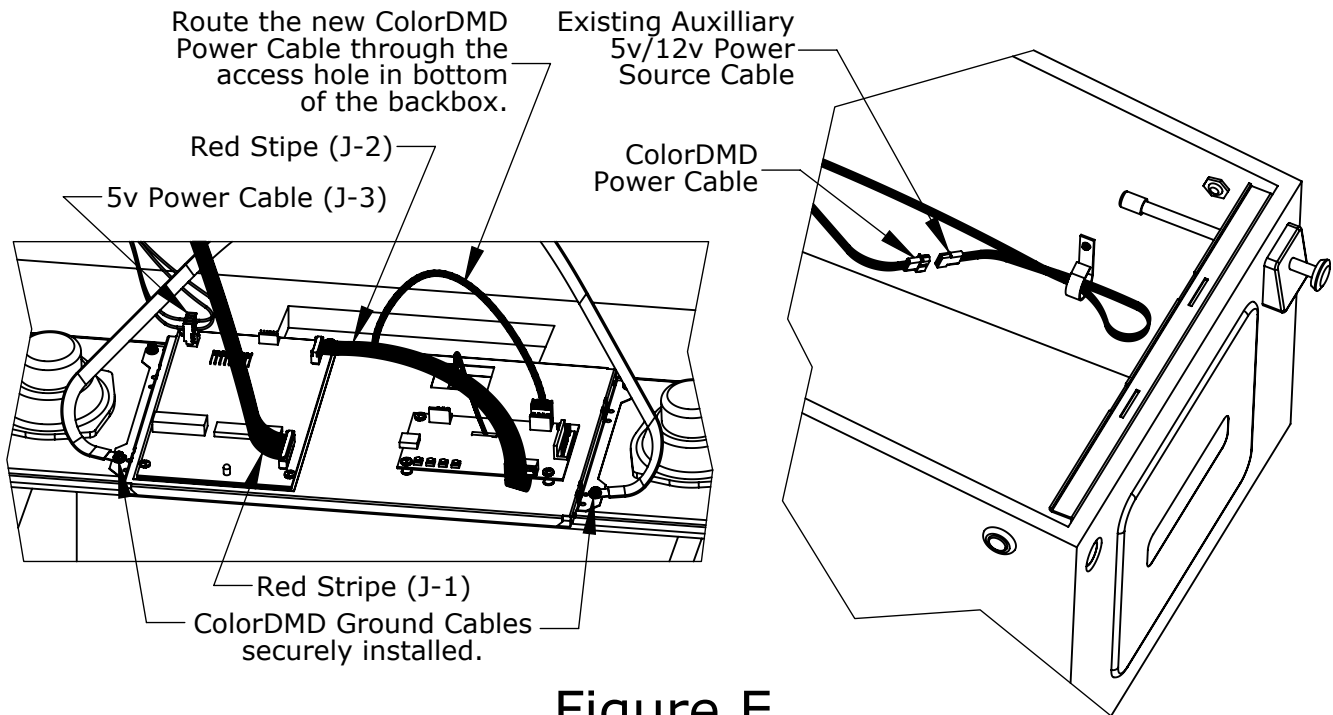

Figure E

TIP Route the new ColorDMD Power Cable inside the cabinet along with other existing cables for a clean install.

- STEP **11** Plug ColorDMD Power Cable into the auxilliary 5v/12v power source connector (See Fig. E). If an existing cable is currently plugged into this connector, disconnect it and plug it into the other end of the ColorDMD Power Cable 'Y' harness (See Fig. D).

- STEP **12** Plug the included 12" ColorDMD 14-Pin ribbon cable into DMD_IN on the ColorDMD with the **red stripe on the right-hand side** (see Fig. F). The other end of this cable should be plugged into J-2 on the Display Controller Board with red stripe facing Up (See Fig. E).

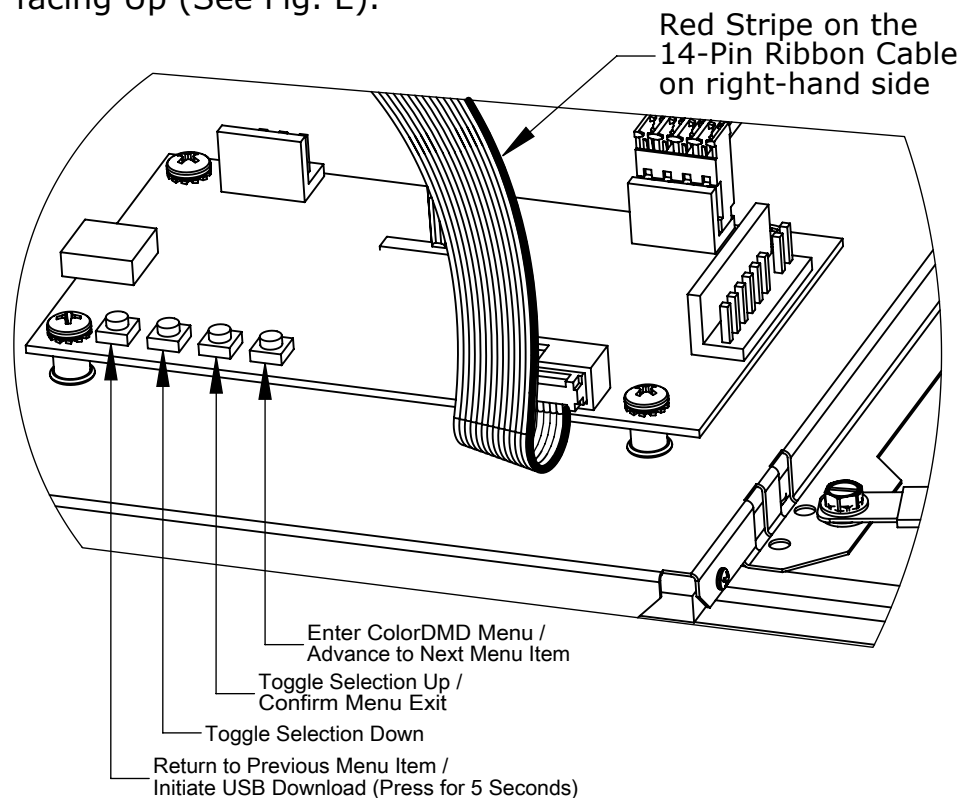

Figure F

- STEP **13** Reconnect the 5v power cable to J-3 and also the 26-pin ribbon cable to J-1 with red stripe facing down (See Fig. E) to the Display Controller Board .



*Double check for proper alignment of **all** cable connections.*

- STEP **14** While ensuring no wires get pinched, raise the speaker panel and turn on the pinball machine.

- STEP **15** Locate and press the right-most *ColorDMD Menu* button (See Fig. F) to customize the display settings. Continue pressing the button to advance to the "MOUNTING" menu. Next use the *Toggle Selection Up* button to change the setting to "WS".

- STEP **16** Press the right-most button to advance to the "EXIT AND SAVE" menu. Press the *Confirm Menu Exit* button to save settings and return to game mode. Video should appear on the new ColorDMD Display. Game is now ready to play. Have fun!

For additional information regarding display settings please visit our website at www.colordmd.com.